

BLUETOOTH KEY·FINGERPRINT

WM-2000C-FBK04

System Description

Vanmalock system bring full-featured access control to every locking point without installing hardwired network or power connections. Vanma® keys are designed with highly durable ABS casings and stainless steel. Each key contains a specific list of authorized locks and schedules of when they may be accessed. Vanma® key energized the cylinder when they touch each other. The programmable, battery powered keys with range of programmable cylinders makes your management more accessible.

Feature

- Programmable electromechanic lock for Vanma® locking system
- No batteries or external energy source required for the lock
- All Vanma® locks and Vanma® keys are mechanically identical
- Powerful and secure AES256 encryption for common lock and key authentication
- Programmable lock opens with Vanma® keys
- Log memory for openings and opening attempts
- Access group list for key accesses
- Updatable firmware



Drawings

Model:WM-2000C-FBK04

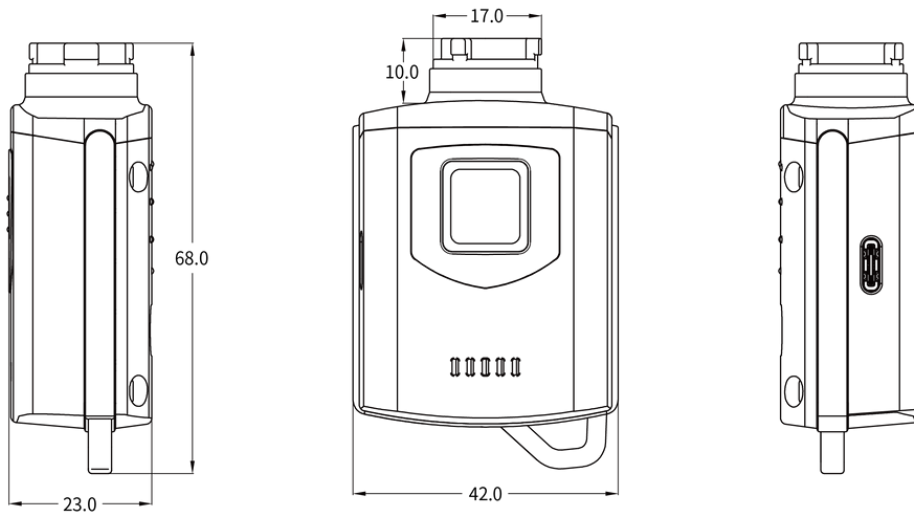

Memory Capacity

- Access Rights.....30, 000 Pcs
- Event Logs.....60, 000 Pcs

Technical Data

- Physical.....Hardened Zinc-Alloy with chrome plating, ABS Plastic
- Weight.....80.4g
- IP Standard.....IP65
- Battery Capacity.....600mAh
- ESD Protection.....8KV contact static/15 KV non-contact static
- Fingerprint Capacity.....100 Groups
- Working Temperature.....-40°C~70°C
- Bluetooth.....BLE 4.2